

# GHBH Series

## GHBH 001 34 1R4

### Technical datasheet



#### Goorui blower performance curves

##### Vacuum selection diagram curve

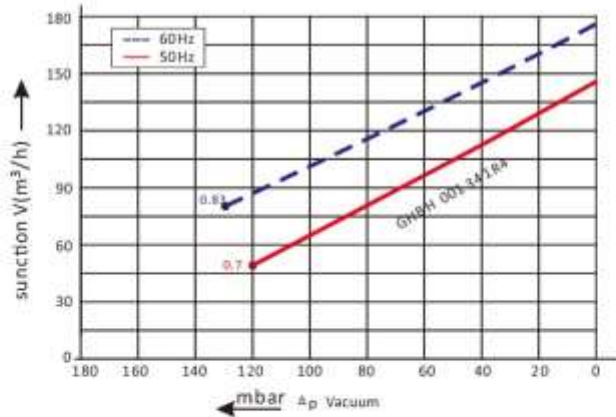

##### Compressor selection diagram curve

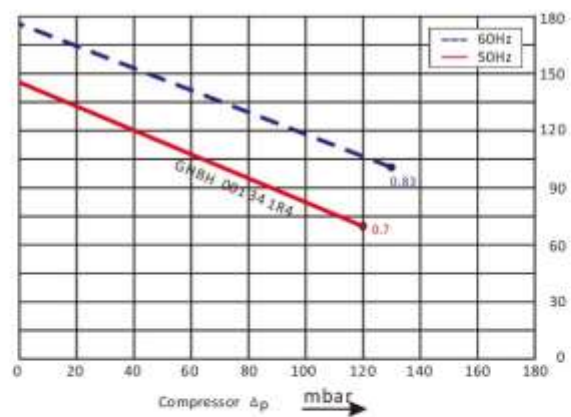

#### Goorui blower installation drawing

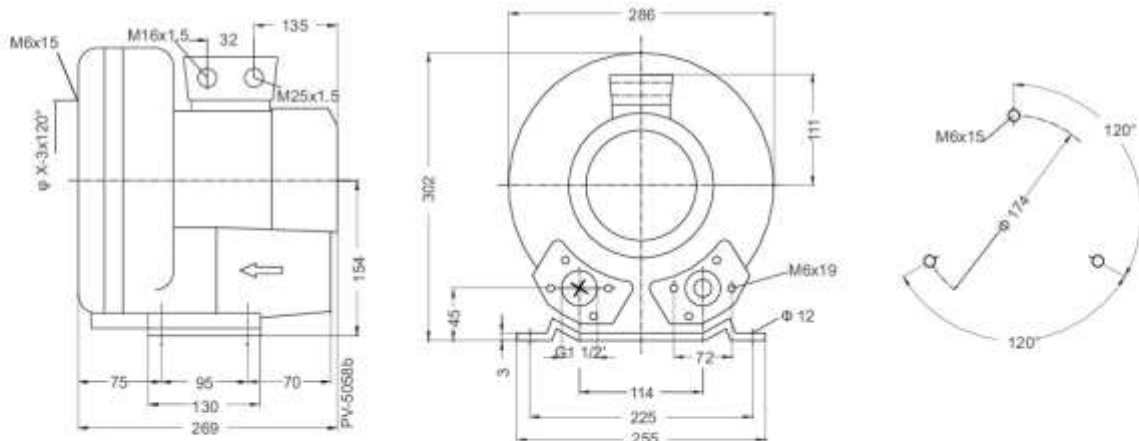

#### Goorui blower parameter

Model	Frequency	Output	voltage	Current	airflow	pressure		noise	Weight
						vacuum	compressor		
	Hz	KW	V	A	$m^3/h$	mbar	mbar	dB(A)	kg
<b>3~ 50/60Hz IP54 INSULATION class F</b>									
GHBH 001 34 1R4	50	0.7	200-240 $\Delta$ /345-415Y	3.8 $\Delta$ /2.2Y	145	-120	120	63	13
GHBH 001 34 1R4	60	0.83	220-275 $\Delta$ /380-480Y	3.75 $\Delta$ /2.15Y	175	-130	130	64	13

The performance curves of Goorui blower is tested through below ways:  
Under one atmospheric pressure, suck 15°C air and then you can calculate the data, of course allow 10% difference, and when the sucked air and surroundings temperature are not higher than 25°C, you still can get total pressure difference as the curves shows.